

**IMPORTANT: Installation must be done by a qualified electrician.**

Please read instructions before proceeding with installation. Keep these instructions for future reference.

**▲ WARNING**

**RISK OF ELECTRIC SHOCK**

- Turn off power prior to inspection, installation or removal of fixture.
- Ensure electrical enclosure is properly grounded in accordance with National Electrical Code (NEC).

**RISK OF FIRE**

- Product must be installed in accordance with NEC and/or applicable local codes by a qualified licensed electrician.
- Wiring connections should be made with UL approved wire connectors.

**THIS PRODUCT MUST BE INSTALLED IN ACCORDANCE WITH THE APPLICABLE INSTALLATION CODE BY A PERSON FAMILIAR WITH THE CONSTRUCTION AND OPERATION OF THE PRODUCT AND THE HAZARDS INVOLVED.**

**VAPOR BARRIER MUST BE SUITABLE FOR 90°C.**

**ATTENTION**

- Use care when handling the luminaire. Do not drop, press, or bend the light panel to avoid damage during installation.
- Work gloves are recommended when handling the LED flat panel to protect hands and prevent the transfer of dirt and oil to the luminaire.
- Prior to installation, carefully unpack and properly inspect luminaire for any damage or loose connections that may have occurred during shipping.

**SPECIFICATIONS**

Input Voltage (V)	120-277V AC
Input Frequency (Hz)	50/60Hz
Dimming/Control	0-10V
Ceilings	9/16" T-Grid, 15/16" T-Grid
Warranty	5 year limited warranty
Operating Temperature Range	-20°C to 40°C
Environmental Rating	Damp location rated
Certifications & Listings	UL, cUL, FCC, Type IC, RoHS, DLC

## LUMINAIRE INSTALLATION

### T-GRID MOUNTING

- Step 1:** Remove existing ceiling panel or light fixture from T-bar ceiling grid.
- Step 2:** Insert the luminaire into the T-bar ceiling grid location.
- Step 3:** Properly secure luminaire as required by applicable state and/or local codes.
- Step 4:** Remove wiring compartment knockout and make wiring connections per the **Electrical Connection** section below.

**NOTE:** For other mounting applications, please refer to the installation instructions provided with the approved mounting kit.

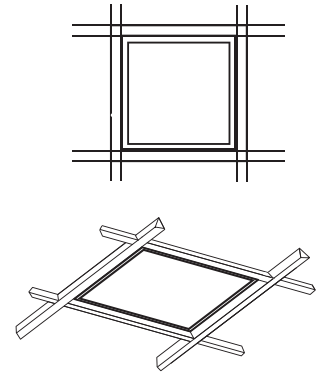

### ELECTRICAL CONNECTION

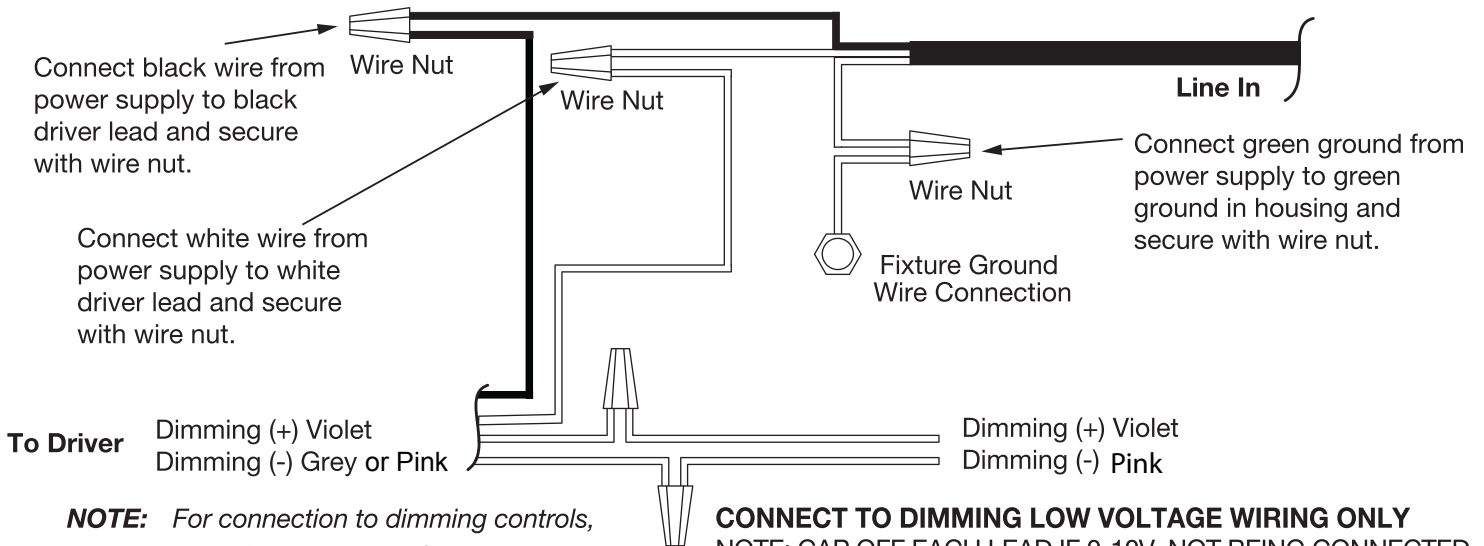

**NOTE:** For connection to dimming controls, consult control manufacturer's wiring instructions.

**CONNECT TO DIMMING LOW VOLTAGE WIRING ONLY**  
NOTE: CAP OFF EACH LEAD IF 0-10V NOT BEING CONNECTED.

**USE ONLY UL LISTED WIRING CONNECTORS AND UL LISTED WIRING HAVING A MINIMUM TEMPERATURE RATING AS SHOWN ON THE FIXTURE LABEL. USE ONLY UL LISTED CORDS. IF SUPPLIED WITH A CORD USE WITH UL LISTED STRAIN RELIEF THAT IS RATED FOR THE CORD.**

These instructions are not intended to cover all details or variations in your equipment or your particular requirements for installation, operation or maintenance. Should further information on this product be needed that is not covered by these general installation instructions, please contact the TCP Customer Service Department at phone number 800-324-1496 for further assistance.

**SAVE THESE INSTRUCTIONS**

## POWER REGULATION

### DT Series Driver

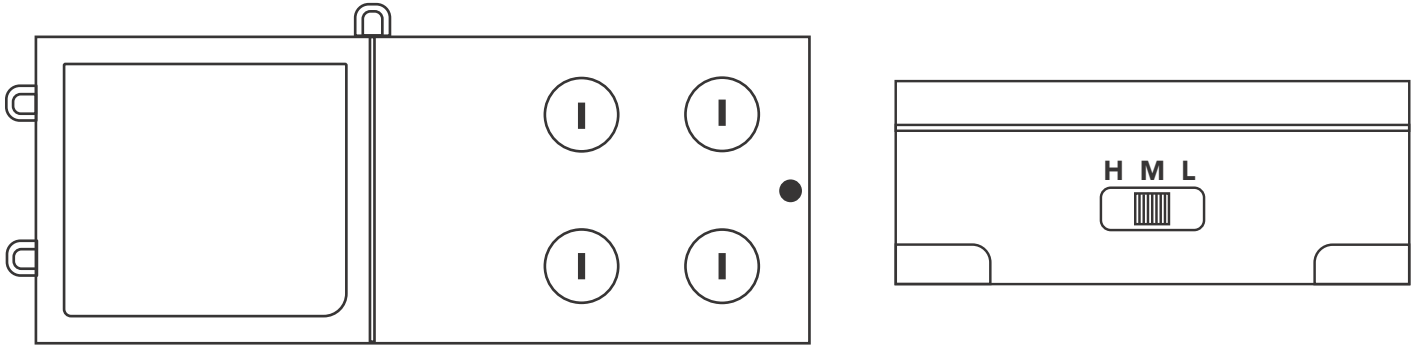

### PLP Series Driver\*

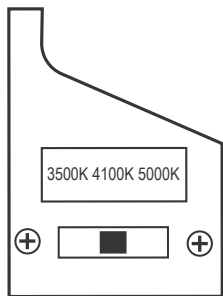
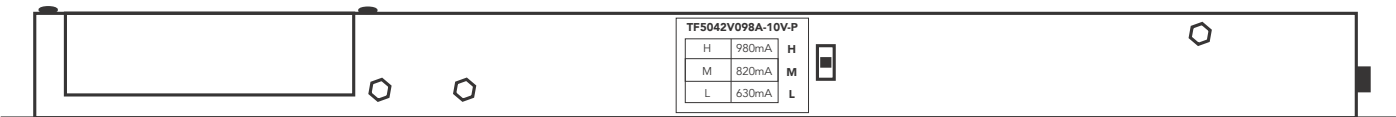

\*Note: Only on color selectable units. Not all PLP drivers will have this option.

These instructions are not intended to cover all details or variations in your equipment or your particular requirements for in maintenance. Should further information on this product be needed that is not covered by these general installation instruction the TCP Customer Service Department at phone number 800-324-1496 for further assistance.

## SAVE THESE INSTRUCTIONS